



EWP[®]115 INSTALLATION INSTRUCTIONS

DAVIES, CRAIG EWP[®] (ELECTRIC WATER PUMP) AND OPTIONS FOR PUMP CONTROL

Congratulations on your purchase of the Davies, Craig EWP[®] which is designed to replace or supplement the existing belt driven mechanical water pump of your engine. Your EWP has very high flow capacity and has the advantage of running at a speed independent of the engine speed. The EWP[®] can also be set to continue running after a hot engine shut down to prevent damaging heat soak. When your EWP[®] is used to replace the mechanical pump, you will notice an increase in engine power and torque, especially at high engine speeds. Automatic gear changes, both up and down, will be smoother.

PLEASE READ THESE INSTRUCTIONS IN THEIR ENTIRETY BEFORE YOU START WORK

ALSO NOTE THAT THE EWP IS A 'CIRCULATION' PUMP IDEAL FOR 'CLOSED CIRCUIT' OPERATION SIMILAR TO AN AUTOMOTIVE COOLING SYSTEM. IT IS NOT A 'SELF-PRIMING' PUMP AND THEREFORE WILL NOT OPERATE WITHOUT A POSITIVE 'HEAD' IN AN 'OPEN' SYSTEM.

EWP[®] COMPONENTS:

<u>No.</u>	<u>Description</u>	<u>Qty.</u>
1.	EWP Pump Assy.	1
2.	Wiring harness with 10A fuse	1
3.	Rubber Sleeves	2
4.	Hose Clamps	2

HARDWARE COMPONENTS:

<u>No.</u>	<u>Description</u>	<u>Qty.</u>
5.	Hardware bag	
	--Relay	1
	--Scotch lock	1
	--Ring Terminal	1
	--Self Tapper	1



SECTION ONE: INSTALLING THE EWP[®]115

- The EWP[®] 115 is best fitted in the lower radiator hose connecting the radiator to the existing mechanical water pump housing and let the hose hold the weight of the pump and it will dampen from vibration too. Check the area for available space and shape of the hose. The section of radiator hose connected to the radiator must be connected to the inlet of the electric pump and the section of radiator hose connected to the original pump/engine block must be connected to the outlet of the electric water pump. The pump inlet is in the centre of the pump. The EWP[®] should be positioned as low as possible to maximise the gravity feed from the radiator and prevent air entering the pump. Alternatively, it can be fitted in the upper hose, but in this case the coolant level must be maintained and now the section of radiator hose connected to the top of the radiator must be connected to the outlet of the electric pump and the section of radiator hose connected

to the engine block must be connected to the inlet of the electric water pump. The pump can be installed in any orientation but to assist air bleeding try to mount the outlet pointing upwards.

2. Add the rubber sleeves if necessary (Item No 3) to the inlet and outlet, if required, to suit your particular hose diameter. If you need more thickness still, contact Davies, Craig and we will ship, free of charge same day, sleeves to suit 2" (50mm) internal diameter hose.
3. Cut out the required section of the radiator hose. Connect the pump inlet and outlet to the appropriate hoses. Connect the pump inlet and outlet to the appropriate hoses ensuring that the pump is oriented in the BEST CORRECT ORIENTATION as shown in Fig 1, page 6 "**BLEEDING THE EWP[®]**" during bleeding. Ensure hose clamps are tight.

Do not bleed the EWP until you install the pump control option and disable the mechanical pump

SECTION TWO: OPTIONS FOR PUMP CONTROL

1. With EWP[®] Digital Controller, P/No - 8020:

Use the EWP[®] digital controller to vary the pump voltage in accordance with coolant temperature for optimum temperature control. Set the temperature of the engine for maximum power or fuel efficiency as you wish. The Digital controller has an in-built function to allow the EWP to run-on after ignition is switched off thus eliminating heat soak. This option is best with the removal of the engine thermostat and the mechanical pump impeller or pump belt. The cabin heater may take a little longer than usual to warm up. This can be improved by installing an Electric Booster Pump (EBP), Part Number 9001 to the heater line.

OR

2. With Davies, Craig Thermal Switch, P/No: 0401:

Combine the EWP[®] with a thermal switch when the EWP[®] is used as a booster pump to the existing mechanical pump to fix an overheating cooling system. With the thermal switch connected to the battery, the EWP[®] will run on after a hot engine shut down, eliminating heat soak. Leave the thermostat in place, but make sure the EWP[®] runs only when the thermostat is open.

OR

3. Continuous running:

Wire the pump direct to the ignition for maximum cooling (race vehicles, very hot climates). This option requires the removal of the Engine thermostat and the mechanical pump impeller or pump belt. This option may also be used for road cars with the thermostat in place with a small hole (suggest 5mm), allowing a small amount of flow to circulate even when the thermostat is closed.

WARNING: When using the Electric Water Pump (EWP) on vehicles using LPG, it is recommended that an Electric Booster Pump (EBP - Davies, Craig part no 9001)) be fitted to the heater circuit to increase the flow through the heater line and therefore eliminate the risk of freezing LPG in the converter.

OPTION 1: REPLACING THE MECHANICAL PUMP WITH THE EWP[®] AND EWP[®] DIGITAL CONTROLLER.

This option will allow adjustment of the engine operating temperature. Lower engine temperature for an increase in power or raise it for better fuel efficiency.

MODIFYING EXISTING PUMP

1. Remove the engine thermostat from the thermostat housing.
2. Refer to the Controller Instructions for details of the controller sensor installation.
3. Re-fit the thermostat housing without the thermostat ensuring that there is no damage to the thermostat housing gasket.

Then either:

1. Remove the existing belt driven water pump.

2. Pull the pump impeller off the belt driven pump shaft. (NOTE: You may need to drill holes through the impeller close to the drive shaft to make it easier to remove.) Be careful not to damage the seal or bearing when removing the impeller. Alternatively, remove vanes from impeller in situ.
3. Re-fit the belt driven water pump housing without the impeller ensuring that there is no damage to the water pump gasket and the pump seal is still retained. Re-fit the water pump belt and tighten to manufacturer's specifications.

Or:

By-pass the belt-drive on the water-pump, if possible, by installing a shorter belt that omits the pump pulley. This option is not possible if the pulley drives a belt-driven fan unless you replace the fan with a Davies, Craig Thematic Fan[®]. For example:

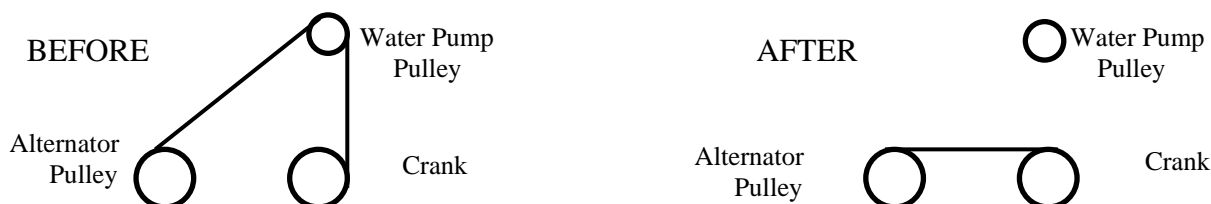

INSTALLING EWP[®] DIGITAL CONTROLLER--Part # 8020

REFER TO EWP DIGITAL CONTROLLER INSTRUCTION SHEETS FOR DETAILED INSTALLATION INSTRUCTIONS.

Do not begin the installation of the EWP Digital Controller prior to the EWP being installed.

NOTE: Wiring from EWP kit will not be required however retain for hard wiring the EWP during bleeding.

1. The controller should be fitted inside the passenger compartment.
2. Connect the wiring harness to the controller and mount the controller (using 2 of the screws provided) in an appropriate position --- *avoid mounting the controller where it may be exposed to direct sunlight.*
3. An additional screw is provided for mounting controller fuse holder where necessary.
4. Mount 'Remote Test Light' in a location, which will be visible. The 'Test Light' may be fitted by inserting it through a 4.6mm drilled hole in a plastic area of the interior/dashboard or simply with adhesive tape.
5. For installation of the sensor in the position of the thermostat refer to the Digital Controller instruction sheets.
6. Bleed the EWP[®]. Refer to **"BLEEDING THE EWP[®]"** on page 6. After bleeding the EWP[®] continue on with the next stage.

RUNNING THE EWP[®]

Start engine to confirm no leakage at radiator hose or sensor and re-torque radiator hose clamps. Monitor the engine temperature, which should take slightly longer than usual to reach steady state.

Using EWP Digital Controller instructions digitally SET the temperature of the engine. It is recommended that initially the 'set point' be set to approximately the mechanical thermostat opening temperature. Generally, running the engine slightly colder will increase the power and running the engine slightly hotter will improve the fuel efficiency. NOTE: Should you wish to run a colder temperature than specified, and then it may be necessary to reduce the temperature setting of electric fan/s operation. Electric fans should not switch on until the EWP is running at full speed and is not holding the target temperature. The EWP Digital Controller has an in-built function to run the EWP after ignition OFF and prevent engine heat soak.

Re-tighten hose clamps after a few hours operation at normal temperature and again after 20 hours running. Check for leaks. The cabin heater may take longer than normal to warm up.

OPTION 2:

USING THE EWP[®] TO BOOST THE COOLING SYSTEM WHEN REQUIRED WITH AN ON/OFF THERMAL SWITCH.

This option when combined with a Davies, Craig Thermal Switch, P/No: 0401 will turn the EWP[®] on at the temperature you set, to give an added boost to an overheating cooling system.

INSTALLING THERMAL SWITCH (Refer wiring diagram 2)

USE DAVIES CRAIG PART NO 0409 TO INSTALL THE SENSOR OR

1. When the engine is cold remove the top radiator hose at the radiator end.
2. Mount the thermal switch on the right angle bracket with the two small self-tapping screws provided. Mount the bracket beside the radiator with the two large self-tapping screws so that the copper bulb will reach the top radiator ferrule (pipe) and so that the switch is available for adjustment.

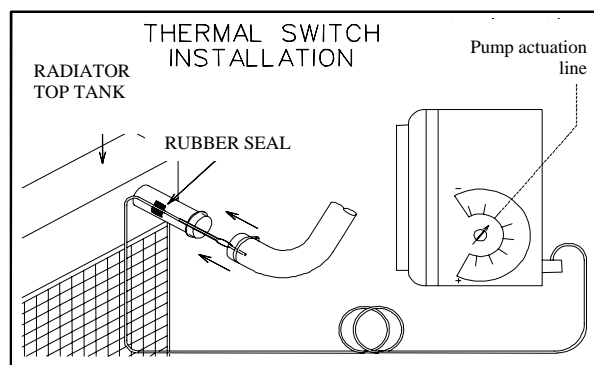

3. Lay the rubber seal along the radiator ferrule and place a section of the copper capillary of the thermal switch down the groove in the rubber seal. Keep the copper capillary loosely coiled and prevent sharp bends. Pass the copper bulb at the end of the capillary down over the radiator inlet ferrule so that it protrudes no more than a few inches into the radiator hose. You may choose to use insulation tape to hold the seal in place while the hose is refitted. Replace radiator hose; position hose clamp across centre of seal with the clamp screw on the opposite side to the capillary. A good silicon type sealant may be used if there is a persistent leak.
4. Connect the pump wiring harness to the pump. Connect the green wire from the relay to the thermal switch. Connect the grey wire provided with the thermal switch to battery positive.
5. Bleed the EWP[®]. Refer to “**BLEEDING THE EWP[®]**” on page 6. After bleeding the EWP[®] continue on with the next stage.

RUNNING THE EWP[®]

Start engine to confirm no leakage at radiator hose or sensor and re-torque radiator hose clamps. Monitor the engine temperature, which should take slightly longer than usual to reach steady state. Adjust the thermal switch dial to turn the EWP[®] on at the temperature desired. With the thermal switch connected directly to the battery, after a hot shut down, the pump will continue to run and prevent engine heat soak.

Re-tighten the clamps after a few hours running at temperature and again after 20 hours running. Check for leaks.

WIRING DIAGRAM 2: EWP[®] WITH THERMAL SWITCH - P/NO: 0401:

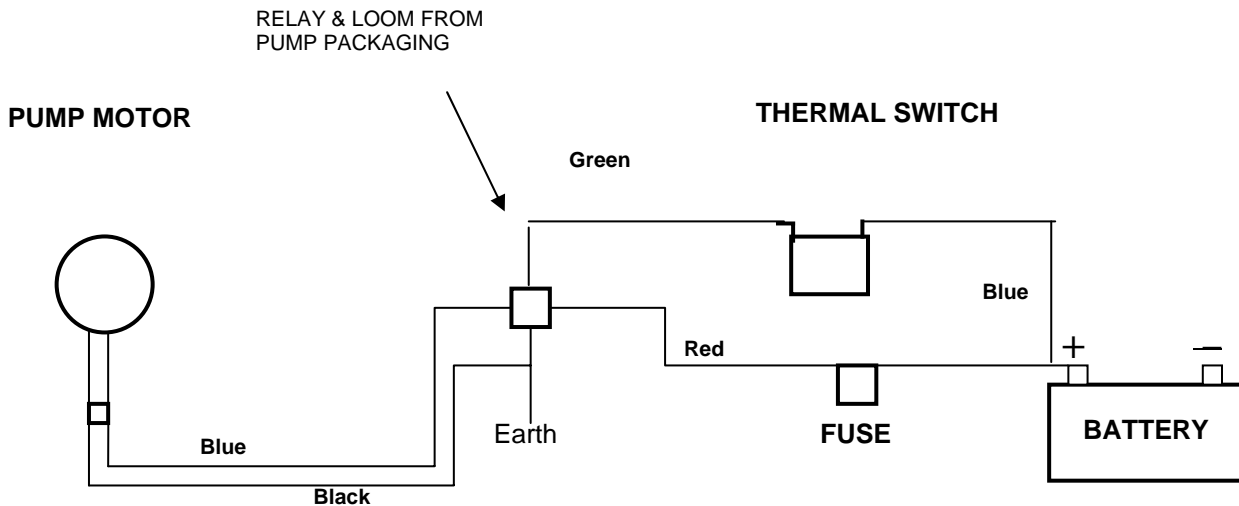

OPTION 3: CONTINUOUS RUNNING (Recommended for race vehicles, very hot climates, and cars running on LPG.)

This option will provide maximum cooling from the pump under all conditions without controller or switch. This method may be used for road vehicles that are not suited to the EWP[®] Digital Controller and engines that run on LPG. Road vehicles choosing this method should retain the thermostat in position with a hole in it (suggest 5mm) to ensure a small amount of flow through the cooling and heating systems at all times.

MODIFYING EXISTING PUMP

1. Either:

1. Remove the existing belt driven water pump.
2. Pull the pump impeller off the pump shaft. (NOTE: You may need to drill holes through the impeller close to the drive shaft to make it easier to remove.) Alternatively, remove vanes from impeller.
3. Re-fit the water pump housing without the impeller ensuring that there is no damage to the water pump gasket and the pump seal is still retained. Re-fit the water pump belt and tighten to manufacturer's specifications.

Or:

1. By-pass the belt drive on the water-pump (if possible) by installing a shorter belt that omits the pump pulley. (Refer example diagram in option 1.)

And:

- a. Remove the thermostat from the thermostat housing.
- b. Re-fit the thermostat housing ensuring that there is no damage to the thermostat-housing gasket.

2. Connect the Pump wiring harness and relay. (Refer wiring diagram 3)

3. Bleed the EWP[®]. Refer to “**BLEEDING THE EWP[®]**” on page 6. After bleeding the EWP[®] continue on with the next stage.

RUNNING THE EWP[®]

Start engine to confirm no leakage at radiator hose and re-torque radiator hose clamps. Monitor the engine temperature, which should take longer than usual to reach steady state. If the ignition is left on (or if a turbo timer is connected) after a hot shut down, the pump will continue to run and stop engine heat soak. Re-tighten the hose clamps after a few hours running at temperature and again after 20 hours running. Check for leaks. NB: The heater circuit may take longer than normal to warm up.

WIRING DIAGRAM 3: EWP[®] CONTINUOUS RUNNING:

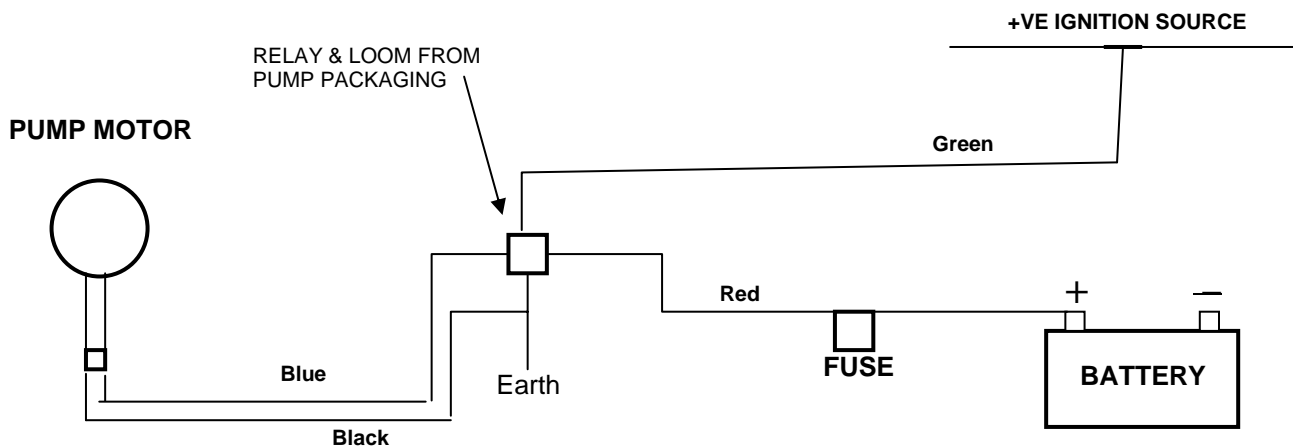

BLEEDING THE EWP[®]

Ensure the EWP[®] is orientated correctly as shown below before continuing and hose clamps are tight.

NOTE: This orientation is a temporary requirement for the purpose of bleeding the pump and ensuring there is no air entrapped within the seal housing of the pump. The pump can be set-up in another orientation upon completion of the bleeding procedure.

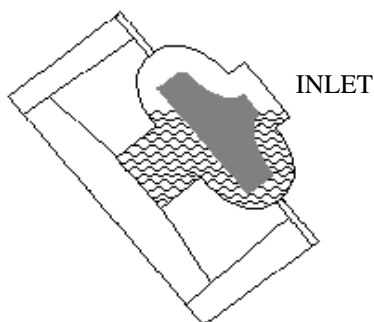

FIGURE 1: BEST ORIENTATION

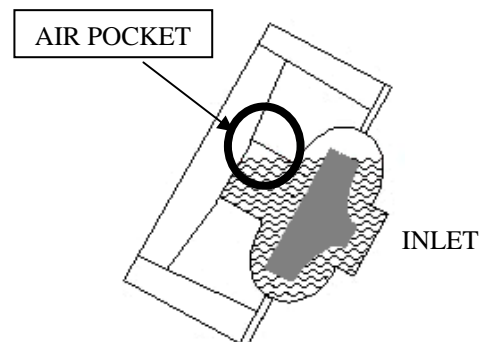

FIGURE 2: INCORRECT ORIENTATION

1. Fill up the cooling system with appropriate coolant.
2. Do not run the engine but hardwire the pump direct to the battery so that the pump runs at full power.
3. With the radiator cap off, run the pump for 5 - 10 minutes to ensure that there is no air trapped in the cooling system. Fill with coolant as the air is removed from the system.
4. Once all air is removed from the cooling system replace the radiator cap and reconnect the pump to your original controlling method.

NOTE: Loosening the hose clamps can change the pump orientation and rotating pump to desired position. If leakage occurs from hoses during re-positioning, the coolant level must be topped up. Ensure that hose clamps are tight.

These installation instructions will suit most situations but there are conditions of engine design, environment, and the kind of motoring involved, which may call for other arrangements not described here. Advice is available from Davies, Craig and we would very much appreciate your feedback.

If you encounter any difficulties during the installation and require further assistance, please contact Davies, Craig on +61 (0)3 9369-1234.

WARNINGS

- Use of the EWP[®] after removing the pump impeller or deleting the mechanical pump pulley from the belt system will increase maximum engine speed. Running an engine at higher speeds than normal may affect other engine components.
- Do not run pump dry as seal damage may occur and your warranty will be void.
- Engine temperature must be monitored closely at all times but especially immediately after installation and until pump operation and capacity have been proved.
- The EWP[®] can handle most rust particles and sludge found in cooling systems but large rust particles should be flushed from the radiator before the EWP[®] is installed.
- Some vehicles may require special bleeding procedures to remove air from the cooling system not described here. The EWP must be completely flooded with coolant at all times to achieve the life specification of the EWP and to preserve warranty.
- Do not use the vehicle's engine management system or wiring connected to the vehicle's engine management system as an ignition source because it may cause failure of the management system and/or the electrical system. The ignition source must be a steady positive supply of 12-14V DC.
- Vehicles with both heater circuit inlet (return) and outlet ports in the mechanical pump housing will suffer reduced heater performance unless the heater returns position is relocated (suggest top radiator hose).
- The cooling system should have antifreeze in accordance to the vehicle manufacturer's specification.
- The EWP is a 'circulation' pump ideal for 'closed circuit' operation found in an automotive cooling system. It is not a 'self-priming' pump and therefore will not operate well without a positive 'head' in an 'open' system
- The impeller tip clearance is very tight for maximum efficiency, and may when new actually scrape the pump housing causing a slight noise. The impeller will bed in over time and the noise cease.

EWP[®] Installation Recommendations

To ensure maximum life and optimum performance from your new EWP[®], Davies, Craig recommends:

- If an EWP[®] is installed on a vehicle which is kept in storage for more than 3 months, for example. a show or race-car, it is advised that the pump be operated for approximately 5mins constant running every month. This will minimise the build up of any sediment in the EWP[®] and also lubricate all parts within the pump.
- For improved heater performance on vehicles which have the heater inlet (return) and outlet ports in the mechanical pump housing (referred to in "Warnings"), Davies, Craig has developed the Electric Booster Pump, EBP[®], part no 9001, which fits into the heater hose and boosts flow through the heater circuit and/or cylinder heads. There is more information on our web page www.daviescraig.com.au

-
- LPG (Liquid Petroleum Gas) vehicles require constant flow through the LPG converter and if the EWP[®] is used in conjunction with the Controller, we recommend the installation of an EBP[®] (Electric Booster Pump) to overcome freezing of the converter body at start up.
 - It is recommended that the cooling system is flushed every 6 months or 10,000kms to remove any built up sediment in the cooling system.

⊕ WARRANTY

We warrant that for a period of two years or 2000 hours continuous running (whichever is the lesser) from the date of purchase, we shall carry out, free of cost, any repairs that are reasonably necessary to correct any fault in the operation of your Electric Water Pump provided that such a fault is directly attributable to a defect in the workmanship or materials used in the manufacture of the part(s) and is not due to installation other than described in these instructions. Labour and consequential costs are excluded

DAVIES, CRAIG PTY. LTD.

28/11/2008

WARRANTY REGISTRATION
Part number 8025 – Electric Water Pump, EWP 115

Name: _____

Address: _____

_____ Post Code: _____

Purchased From: _____ Date: _____

Fitted to vehicle: _____ Year: _____

Comments: _____

Mail to: Davies,Craig Pty Ltd, P O Box 363, Altona North, Victoria, Australia 3025

OR REGISTER ON-LINE AT www.daviescraig.com.au